



Leaders in Reception Seating

Lesro Industries, Inc.
1 Griffin Road South
Bloomfield, CT
06002

Phone
860.243.3226
Fax
860.243.5392
www.lesro.com

Assembly Instructions For Steel Frame Conference Tables

(All shapes and sizes except 84" and 96")

Tools required: Allen wrench (included in hardware pack). A Phillips screwdriver is required for models with shelf.

Note: These instructions are intended for various shapes, models and configurations. Your product may not look exactly as shown in the diagrams.

Recommendation: Retighten all screws and bolts on a seasonal basis to ensure your product remains strong and stable for many years of use.

Weight Capacity: These tables are not intended for use as seats.

Parts List

Tabletop
Legs, 4 pcs.
Cross Tubes, 2 pcs.
Center 'H' Frame
Shelf (optional)

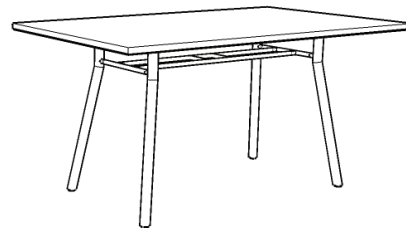

Table without Optional Shelf

Hardware Pack

1" Allen Bolts, 16 pcs.
Washers, 16 pcs.
1/2" Allen Bolts, 8 pcs.
Allen Wrench
3/4" Screws for Optional Shelf

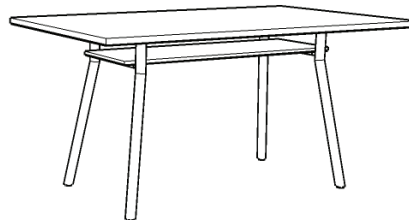

Table with Optional Shelf

1. Unpack and identify all parts.
2. Place the tabletop upside down on a soft, clean surface to prevent scratches.
3. Attach one leg to tabletop using 1" Allen bolts and washers into threaded inserts, as shown in figure 1. Be sure leg angles out and short connecting post is parallel to tabletop reinforcing plate. Keep bolts slightly loose for now.
4. Connect cross tube to connecting post on first leg using 1/2" Allen bolt, as shown in figure 2. Be sure the 2 connecting posts on cross tube face the center of table. Keep bolt slightly loose for now.
5. Connect second leg to cross tube and tabletop, and also connect third leg to tabletop, as shown in figure 3. Keep all bolts slightly loose for now.

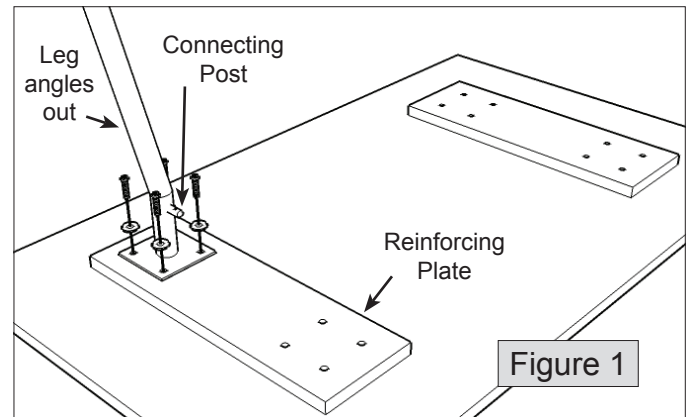

Figure 1

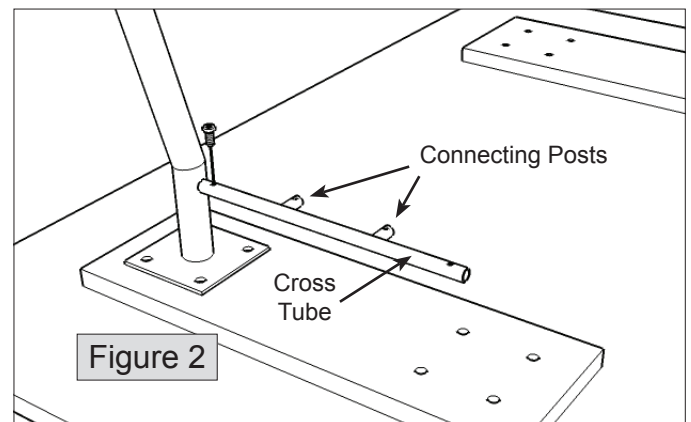

Figure 2

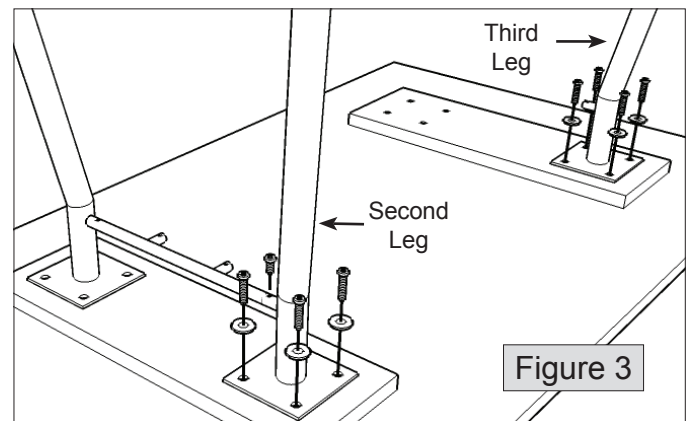

Figure 3

Thank you for purchasing a Lesro product.
Need assistance with assembly? Call Lesro customer service 1-800-275-7545.
Visit us on-line at www.lesro.com

Assembly Instructions For Steel Frame Conference Tables (All shapes and sizes except 84" and 96")

Optional Shelf – If your table came with a shelf, now is the time to insert it.

- A. Using 2 or more people, carefully place the shelf between the 3 legs with the finished surface facing the tabletop, as shown in figure 4. Use care in handling to avoid damage. Suggestion: Place soft cloths or similar material between tabletop and shelf to prevent scratches. Allow the shelf to rest on the tabletop. Continue with table assembly step 6.

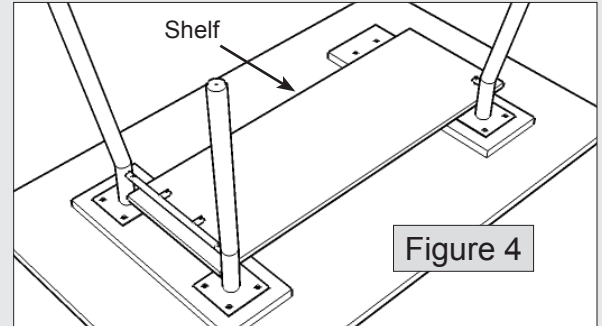

6. Connect 'H' frame to first cross tube and connect second cross tube to 'H' frame and to third leg as shown in figure 5. Keep all bolts slightly loose for now.
7. Connect fourth leg to second cross tube and to tabletop, also as shown in figure 5.
8. Tighten all leg and cross tube bolts securely at this time.
9. Using 2 or more people, carefully flip table to upright position. **Important:** If you have a table with shelf, use care that shelf does not slide out when flipping table or damage may occur.
10. If your table has a shelf, please continue with shelf installation instructions below. If your table does not have a shelf, it is now assembled and ready to use.

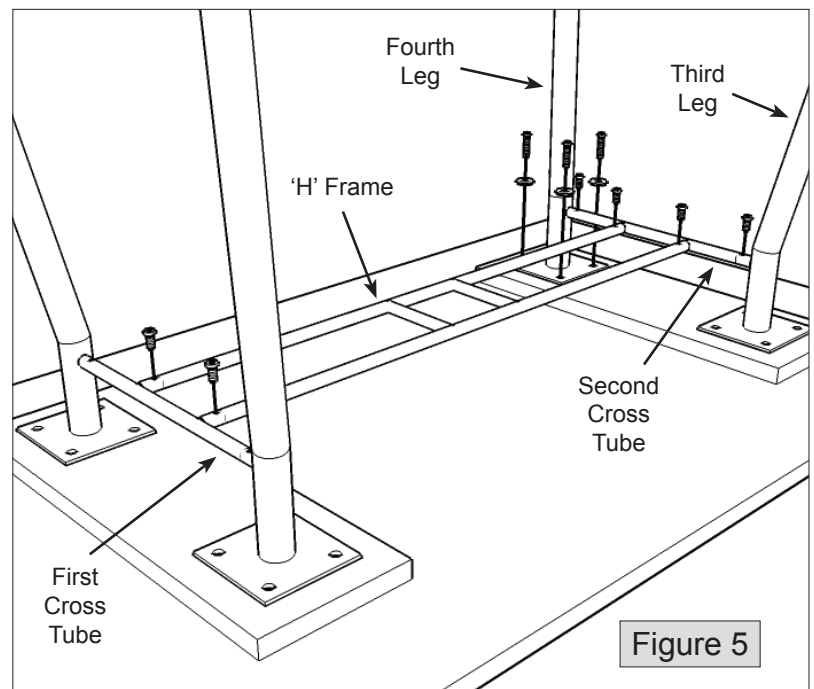

Optional Shelf – If your table came with a shelf, now is the time to screw it into place.

- B. Table should be fully assembled and in the upright position before screwing shelf in place. All leg bolts should be tightened securely before starting.
- C. Center the shelf accurately between leg frames.
- D. Attach shelf to cross tubes using wood screws as shown in figure 6. Tighten all screws securely using care not to strip.
- E. Your product is now assembled and ready to use.

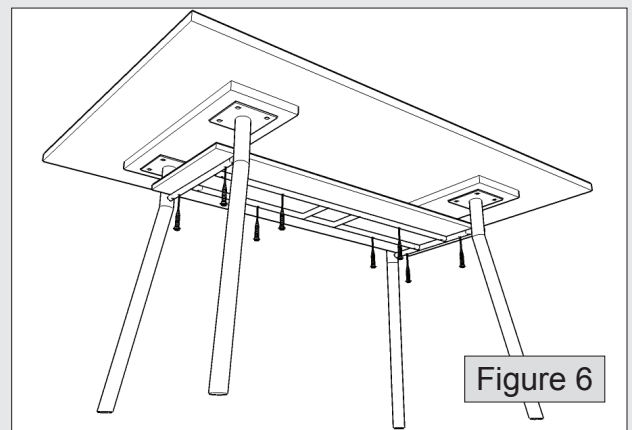

Thank you for purchasing a Lesro product.
Need assistance with assembly? Call Lesro customer service 1-800-275-7545.
Visit us on-line at www.lesro.com